

ECO.37s+

Magnetic drilling machine

EUROBOOR
FOR PROFESSIONALS BY PROFESSIONALS

Technical data

	Metric	Imperial
Annular cutting	Ø 12 - 30 mm	Ø 1/2" - 1 3/16"
Annular TCT cutting	Ø 12 - 37 mm	Ø 1/2" - 1 7/16"
Twist drilling (Weldon)	Ø 1 - 13 mm	Ø 1/16" - 1/2"
Countersinking	Ø 10 - 35 mm	Ø 3/8" - 1 3/8"
Length	275 mm	10 13/16"
Width	190 mm	7 1/2"
Height	293 - 383 mm	11 9/16" - 15 1/16"
Stroke	90 mm	3 9/16"
Weight*	8.5 kg	18.7 lbs
Magnet (l x w x h)	160 x 80 x 37 mm	6 5/16" x 3 1/8" x 1 7/16"
Magnetic force	1,200 kg	2,645 lbs
Motor power	900 W	8.2 A
Total power	950 W	8.6 A
Speed (no load)		775 rpm
Speed (load 900 W, 8.2 A)		400 rpm
Spindle (Weldon)	19.05 mm	3/4"
Voltage		110 - 120 V / 60 Hz 220 - 240 V / 50 - 60 Hz

* Without power cord and handles

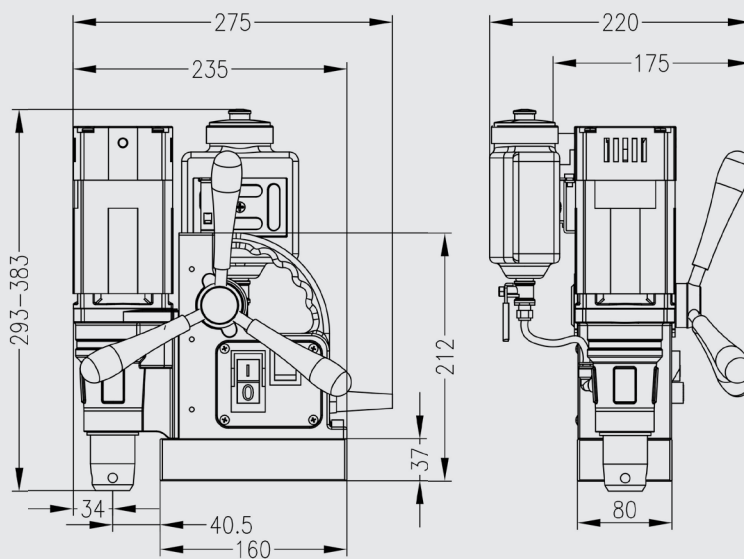

Features

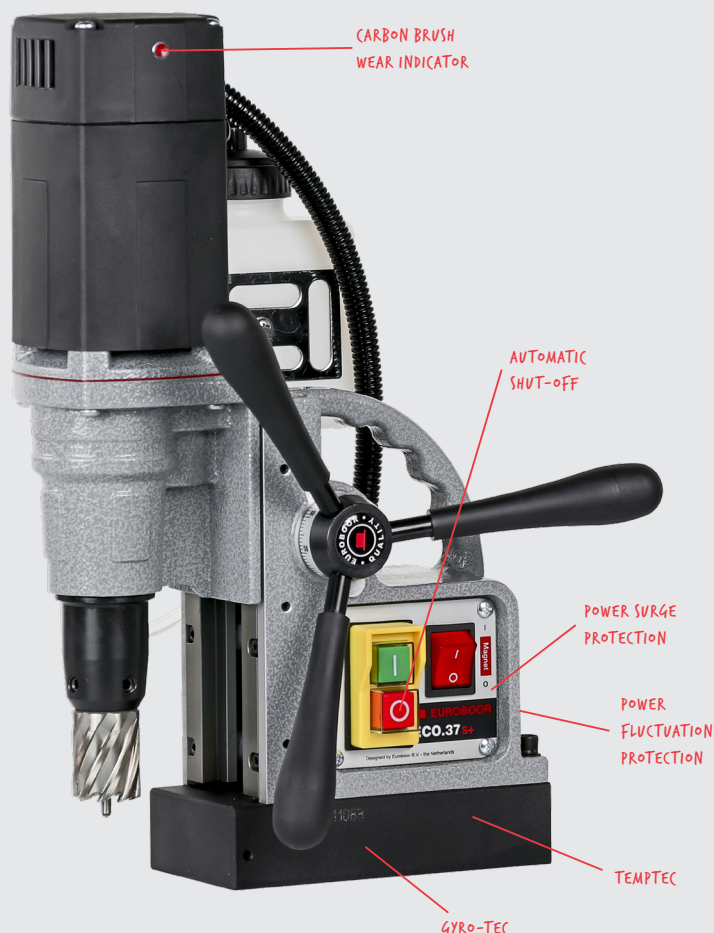
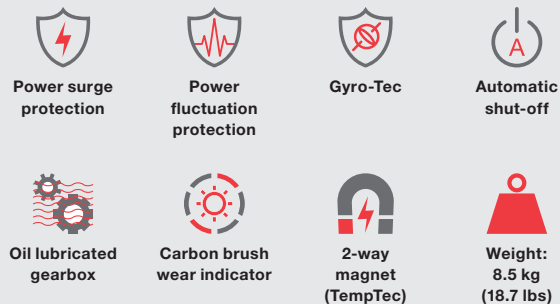

Euroboor makes every effort to meet quality and integrity requirements. That is why we as an organization are proud of the recognition of some leading organizations worldwide:



www.euroboor.com